

Lieferumfang:
 - ungebohrt
 - grundiert RAL 9005 (schwarz)

Laufspiel im Neuzustand:
 - Axial 0,2 bis 0,5 mm
 - Radial 0,2 bis 0,4 mm

Scope of delivery:
 - undrilled
 - primed RAL 9005 (black)

Backlash in new condition:
 - Axial 0,2 until 0,5 mm
 - Radial 0,2 until 0,4 mm

Typ type	ØA mm	ØB mm	ØC mm	ØD mm	ØE mm	ØF mm	Gewicht kg	zul. Axiallast permitted axial load kN
400 L	400	342	292	230	375	260	11	7
500 L	500	442	392	330	475	360	15	9
650 L	650	592	542	480	625	510	20	15
750 L	750	692	642	580	725	610	23	18
850 L	850	792	742	680	825	710	27	25
950 L	950	892	842	780	925	810	30	30
1050 L	1050	992	942	880	1025	910	34	35

Montage- und Betriebsanleitung beachten
 Please note the installation and operation instructions

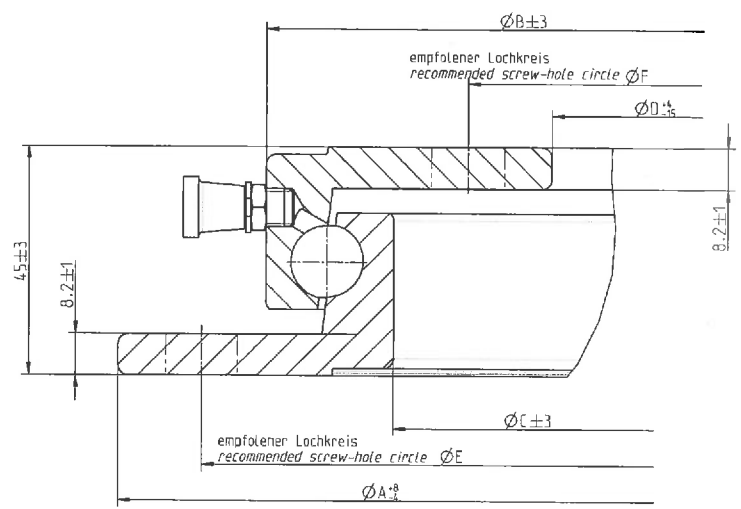
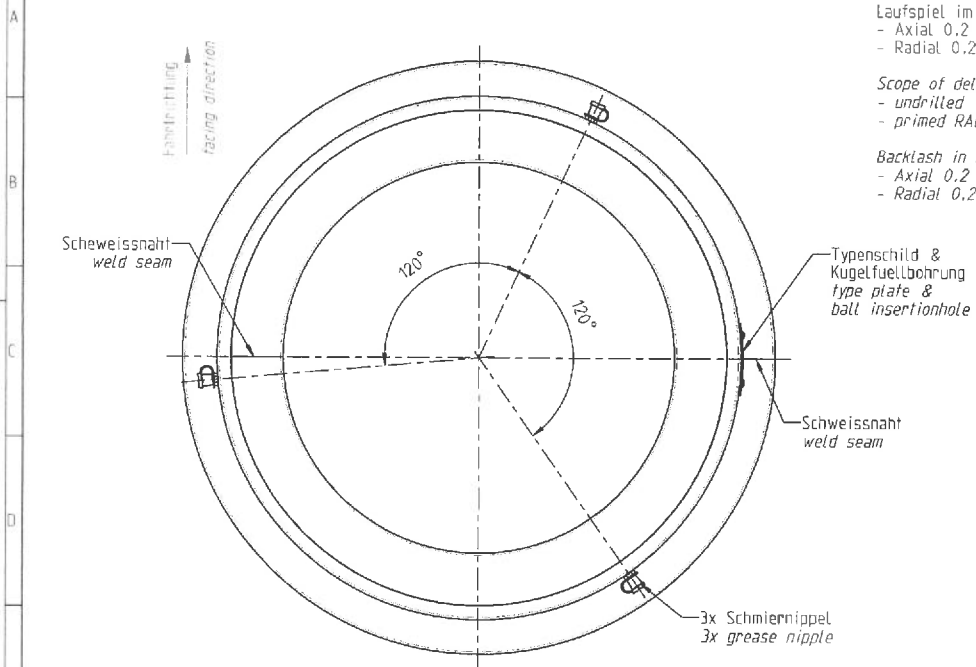

Nur Typ 400 L
 only type 400 L

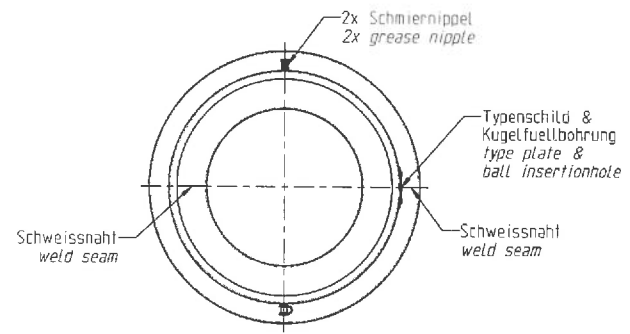

Nur zur Information
 only for information